



NEW

*The world's most advanced  
professional motion picture projector*

**NORELCO**  
**AAII**  
**UNIVERSAL**  
**70/35mm**  
**PROJECTOR**

*For 70mm or 35mm process...  
for indoor or outdoor theatres*

**Norelco**<sup>®</sup>

MOTION  
PICTURE  
EQUIPMENT  
DIVISION



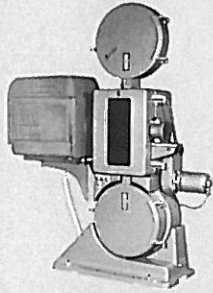

**The Norelco AAll Universal 70/35mm projector** is the newest and most advanced version of the first projector ever built specifically for dual-purpose 70mm and 35mm film projection. Developed in 1954 in cooperation with Todd-AO and the American Optical Company, the original Universal 70/35 is the most widely proven projector of its type in the industry and is currently in use in more than 500 leading theatres throughout the world. The overwhelming preference for Norelco 70mm equipment was recently demonstrated when a major 70mm film was opened at some 50 theatres in the United States. 85% of these theatres were equipped with Norelco projectors.

The breathtaking impact and realism of the large modern motion picture screen has been the most effective answer to competition from the home television screen. As the size of screens grew, they required more and more light as well as improved sharpness and steadiness. Better sound reproduction was another factor essential to making the medium as ideally entertaining as possible. The natural answer to all these needs was the 70mm projection and its 6 track stereophonic sound system.

The aperture of the Norelco 70mm projector has an area 3 to 4 times larger than a conventional 35mm aperture. This means that 70mm film is capable of admitting from 3 to 4 times more light than 35mm film. The definition of the projected image on the screen is correspondingly sharper due to the proportionately lower magnification necessary. For example, in projecting a 44 foot picture with 70mm film, the rate of magnification is 80,400 times. With standard aperture 35mm film, the magnification is 406,000 times—or more than 5 times as much.

*Actual size frame of 35mm film*  
(1.85: 1 WIDESCREEN RATIO)



*Actual size frame of 70mm film*



- 70mm picture area is actually 4 times greater than 35mm.
- Magnification with 70mm film is only about 1/4th as much.
- 70mm aperture allows about 4 times more light to pass.
- A frame of 35mm film has to be blown up over 2 million times to fill a typical 100' drive-in-screen.

## Some outstanding advantages of the Norelco AAll 70/35 projector

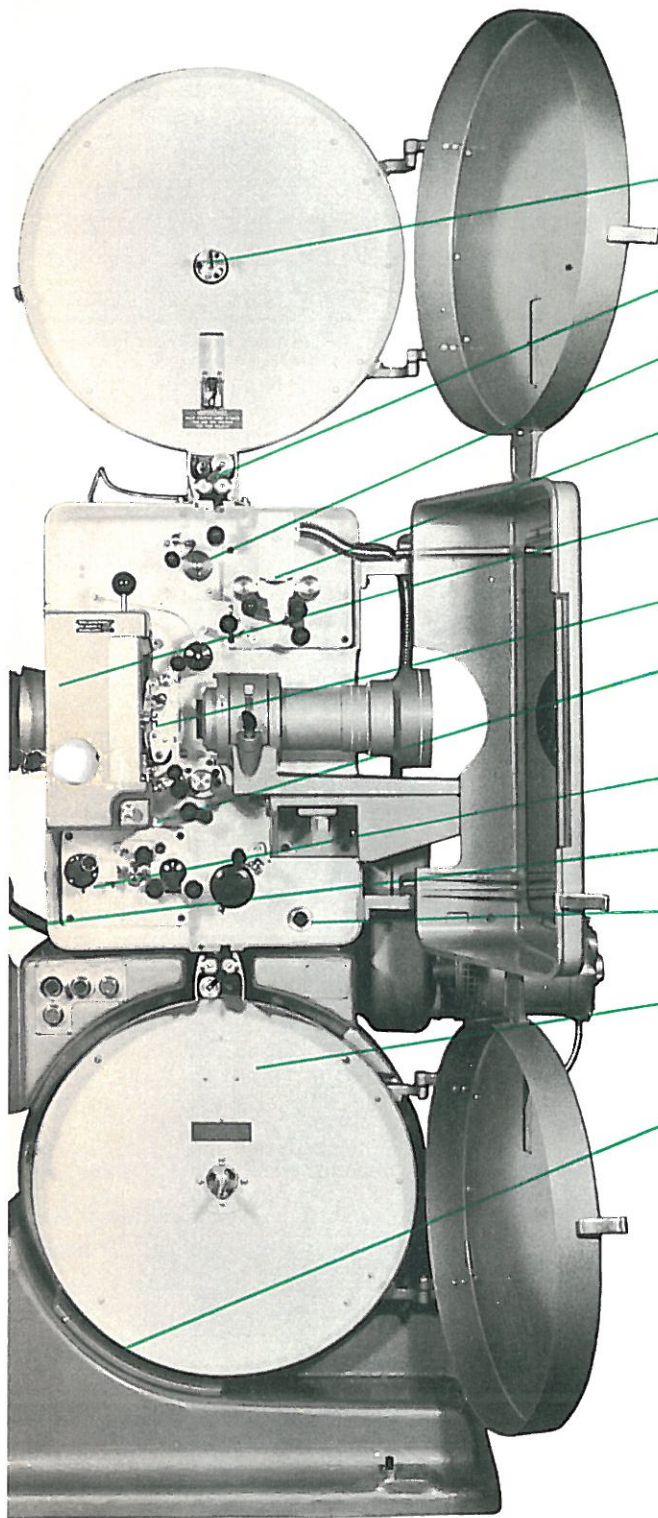

- Dual split 70/35 upper and lower magazine shafts.
- Dual purpose 70/35 ball bearing fire trap rollers.
- Easy, roomy threading. Smallest number of parts in the film path.
- Fully compatible with, and quickly convertible for 70mm or 35mm film with up to 6 magnetic sound tracks.
- Single blade, double speed conical shutter provides highest light transmission.
- Curved film gate controls film buckle.
- Rollers, drums, sprockets and film gate made from non-magnetic materials—eliminates possibility of magnetic sound track damage and necessity for frequent degaussing.
- Optical and magnetic sound heads on same frame with projector.
- All modern, high powered arc lamps adaptable without loss of efficiency.
- Triple filtered metered lubrication system.
- Magazines on same frame with projector.
- Adjustable for all projection angles—from 28 degrees downward, to upward angles required for drive-ins.

### IMPORTANT NEW FEATURES OF THE MODEL AAll 70/35 PROJECTOR

Dual split 70/35 magazine shafts. Standard 5" hub 35mm reels useable. No longer necessary for theatre to purchase special 35mm reels with 70mm flanges. ● New non-glare plexiglass observation window in projector door. ● New threading guards on magnetic shield and idler roller. ● New improved intermittent assembly. ● New oil vapor leak protection. ● New dowser assembly. ● Simplified built-in water cooling circuit. ● Heavier main drive gear set. ● New single motor drive. ● New 2-speed clutch for both 30 Frames/Sec. & 24 Frames/Sec. film speed with double "V" belt drive. ● New reduced torque motor. ● New 4-pole motor start contactor. ● Optional optical pre-amplifier. ● New easy installation lower compartment door. ● New cast aluminum lamphouse bracket with **adjustable slide** for easy alignment of lamp. Provides means for moving lamp without necessity for realignment. Eliminates need for purchase of special adapter previously required for lamps. ● New spiral gear take-up drive. ● New graphite impregnated nylon idler & pad rollers. ● New pre-wired magnetic cluster block.

The 1962 Academy of Motion Picture Arts and Sciences presented this award for outstanding achievement to the North American Philips Company for the design and engineering of the Norelco Universal 70/35mm motion picture projector.

© AMPAS





A typical projection room with Norelco equipment. This is one of more than 500 Norelco Universal 70/35 installations in the United States and throughout the world.

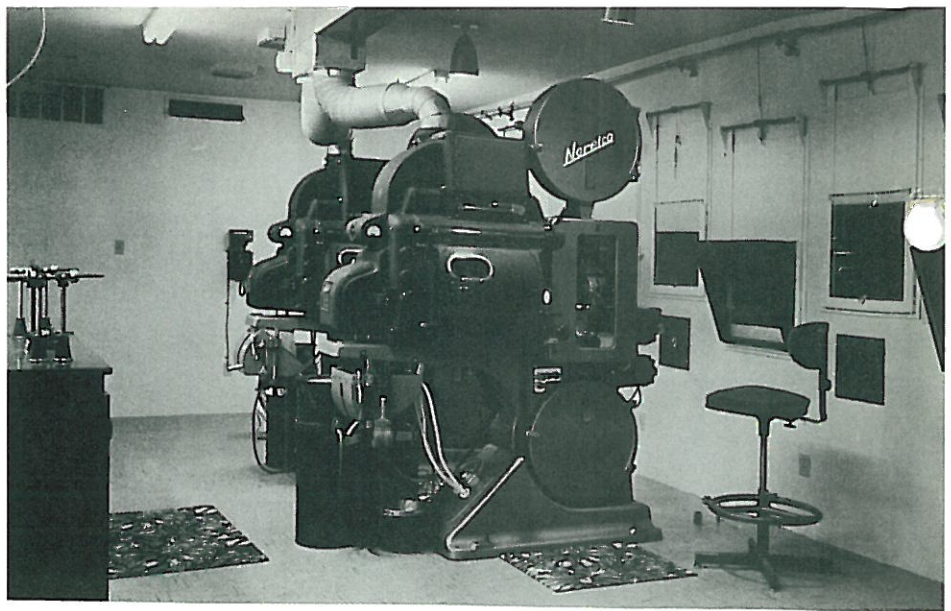

## OVER 500 *Norelco* 70/35 INSTALLATIONS

The day-in and day-out dependability of Norelco 70/35 projectors has been demonstrated during the past 8 years in over 500 fine theatres, studios and laboratories throughout the world. The 70/35 projector is suitable for use with all 70mm film systems such as Todd-AO, Super Technirama, Cinerama 70, Panavision 70, Grandeur 70 and Camera 65 and all the usual 35mm systems in which the film travels vertically, such as standard 1:1.37, Cinemascope with optical sound tracks, Cinemascope with 4 magnetic tracks, Mag-optical prints and the various wide screen ratios. This versatility has been made possible by designing the projector specifically for both 70mm and 35mm film.

**SIMPLE CHANGEOVERS** from one film size to another in less than 4 minutes are made possible because of the few steps required. Errors that could result in film damage are practically impossible. For example, the sprockets (Fig. 1), all of the idler rollers and the fire-traps are suitable for both 70mm and 35mm films without any alteration. The magnetic cluster (Fig. 2) and the sound drums are suitable for 6 track 70mm prints and 4 track 35mm magnetic prints without change . . . and use the same threading path. A handy storage case (Fig. 3), contains all the necessary parts for changing between 70mm to 35mm. The case is fitted with a holding pin for each item and a quick glance suffices to determine the state of the conversion.

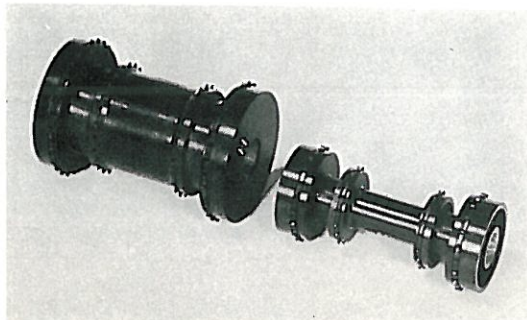

Fig. 1. Holdback and intermittent sprockets

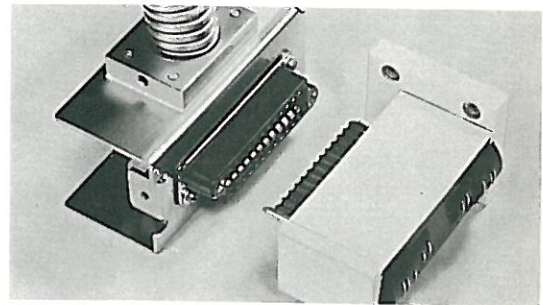

Fig. 2. Magnetic cluster

The case also contains an assortment of aperture plates for fitting to all of the 70 and 35mm screen ratios. Because of the efficient water cooling, the aperture plate remains so cool that it can be replaced very quickly and without tools. Lenses can also be exchanged rapidly. Focusing is not altered when the lens is changed and the difference between the position of the picture center lines of 70 and 35mm films is automatically compensated for. The film speed can be quickly changed from 24 to 30 frames per second so that all 70mm films can be projected.

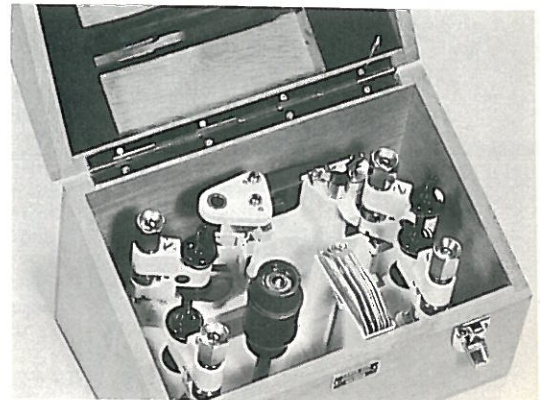

Fig. 3. 35mm conversion chest



## SUPERIOR ENGINEERING

70mm film makes very large demands on a projector. Not only is the film twice as wide, but the height of each frame is 5 perforations instead of 4, so that at 24 frames/sec. the film speed is 25% faster than normal, and at 30 frames/sec. 56% faster. The forces arising during the film transport are therefore greater.

All this has been taken fully into account in the construction of the NORELCO 70/35. The design of Norelco's curved film gate (Fig. 4) adds stiffness to the film in a direction transverse to that of its travel. This prevents the film from buckling in and out of focus and keeps the image sharp on the screen. The shaft for the intermittent sprocket (Fig. 5) is supported by bearings on both sides of the sprocket and the projector, as well as the base and the lamphouse bracket, are all of very sturdy construction, preventing vibrations due to the accelerated film speed.

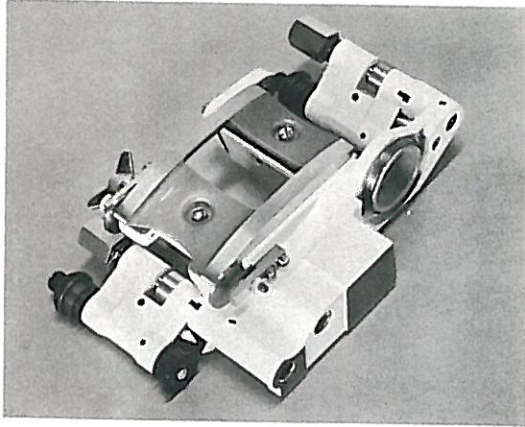

Fig. 4. Curved film gate

The lens holder (Fig. 6) is also very solidly built in order to keep the big (4") lenses needed for 70mm projection free from vibration, and in order to be able to focus them with the greatest possible accuracy. All shafts and gear-wheels are over-sized. The use of exclusively spiral gear transmission with alternate steel and novotex wheels ensures quiet running (Fig. 7). The mechanism is powered by a new single motor dual speed drive. (Fig. 8)

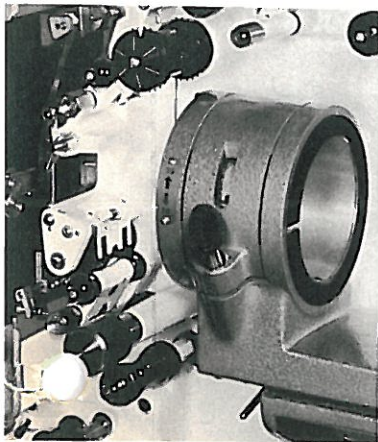

Fig. 6. Lens holder

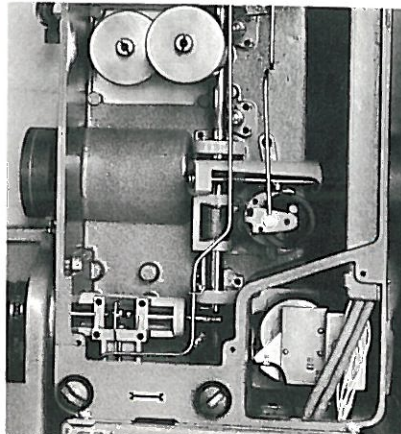

Fig. 7. Interior of gear box

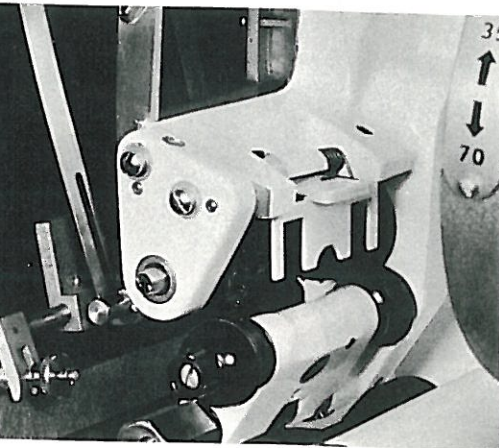

Fig. 5. Shaft for intermittent sprocket

The whole mechanism is thoroughly lubricated automatically by a built-in gear-wheel oil pump. Intermittent mechanism oil is constantly renewed by a freshly filtered supply. Magnets in the filter provide added wear protection.

The life of the projector constructed in this way is even longer than that of a normal 35mm projector, despite the heavier load imposed on it by the 70mm film.

Because of the greater cost of 70mm prints, special care has been taken with the design and construction of the film path. The number of rollers has been kept to a minimum. The fire-trap rollers (Fig. 9) run on ball bearings. All rollers are grooved, so that scratching is impossible. A large number of teeth of the 30-tooth sprockets are always engaged, so that strain on the perforations is almost non-existent. And film life is remarkably long with runs of **2,000 per print** not uncommon!

## MAXIMUM LIGHT NEEDED

The tremendous amount of heat generated by the light needed to project the big 70mm pictures in theatres and drive-ins is efficiently dissipated by the combined water and air cooling systems of the Norelco 70/35. Designed to accommodate all well known types of arc lamps, the projector is so constructed that even for the biggest lamps the beam reaches the aperture plate without obstruction.

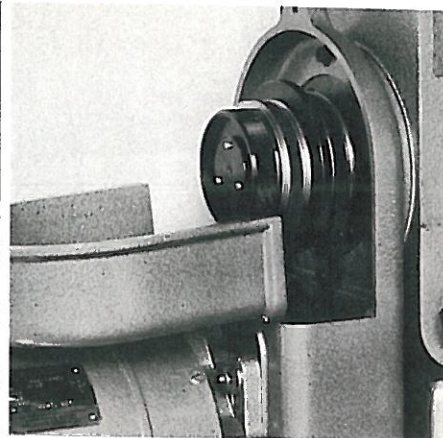

Fig. 8. Single motor dual speed drive

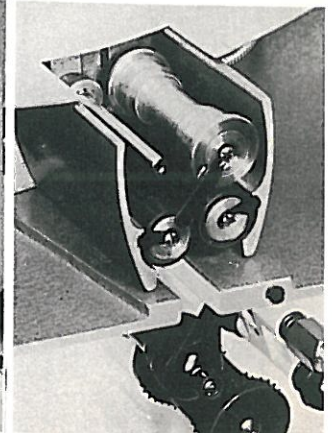

Fig. 9. Fire trap rollers



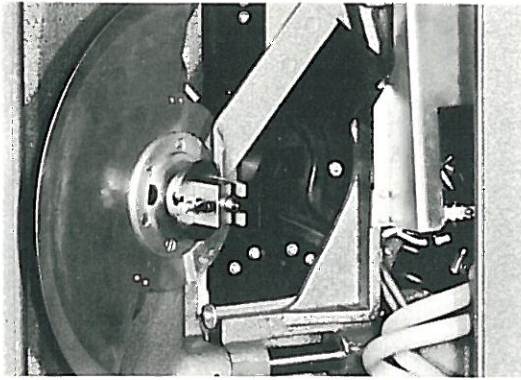

Fig. 10. Single blade, double speed conical shutter

The single blade, double speed conical shutter (Fig. 10) provides the highest light transmission efficiency. It is constructed with air scoops on leading and trailing edges that also assist in dissipating heat.

## MAGNETIC SOUND HEAD

Magnetic sound reproduction is completely free from wow and flutter. This is due to the gear driven

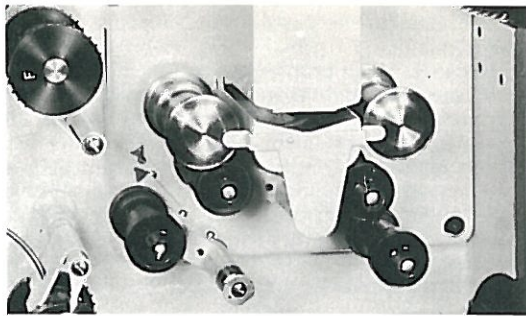

Fig. 11. Magnetic sound head

sprocket between the upper magazine and the sound head, (Fig. 11) the use of two statically and dynamically balanced flywheels and a carefully designed filter.

The flanged drums located one each side of and close to the magnetic cluster are a NORELCO exclusive. These assure positive alignment of the sound tracks with the pick up head. This careful design feature eliminates cross-talk and volume variations due to film weave or mis-tracking.

## OPTICAL SOUND HEAD

Equal care has been taken with the optical sound head (Fig. 12) for 35mm film, a unique NORELCO design whereby the film itself acts as a practically inertia-free buffer, eliminating all the irregularities caused by the teeth of the take-up sprocket engaging in the film perforations. The sound track is projected with a magnification of 13.5 on the scanning slit. The magnified sound track is visible through an inspection window, so that the correct position of the sound track with respect to the slit can be accurately adjusted. The film is supported for its full 35mm width, eliminating the disadvantage of the sound track extending beyond the drum, unsupported.

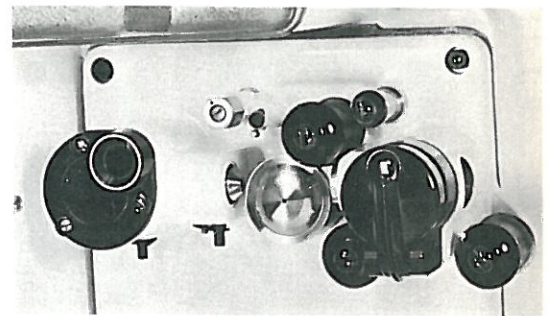
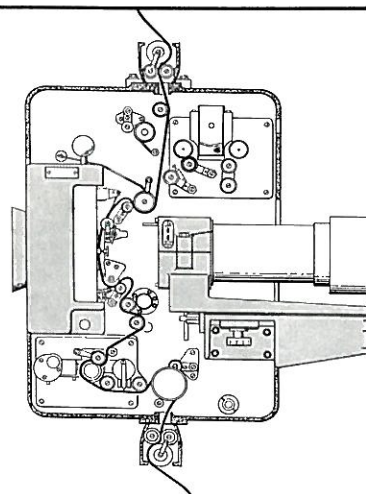
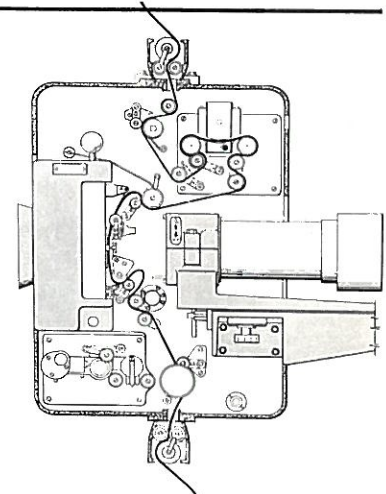

Fig. 12. Optical sound head

## SIMPLE THREADING



Threading Diagram 35mm optical



Threading Diagram 70mm magnetic

The small number of rollers and their logical, well spaced arrangement, makes threading simple and fast. The pad rollers are closed by pressing a button. The pressure in the film gate can be adjusted by a single control. The lenses are quickly and easily replaced without a change in focus. The projector is switched on and off by built-in push buttons.

Well spaced components, smooth lacquer finish and rounded contours permit easy cleaning of the mechanism. The major lubrication necessary consists of changing the oil once every 250 hours.

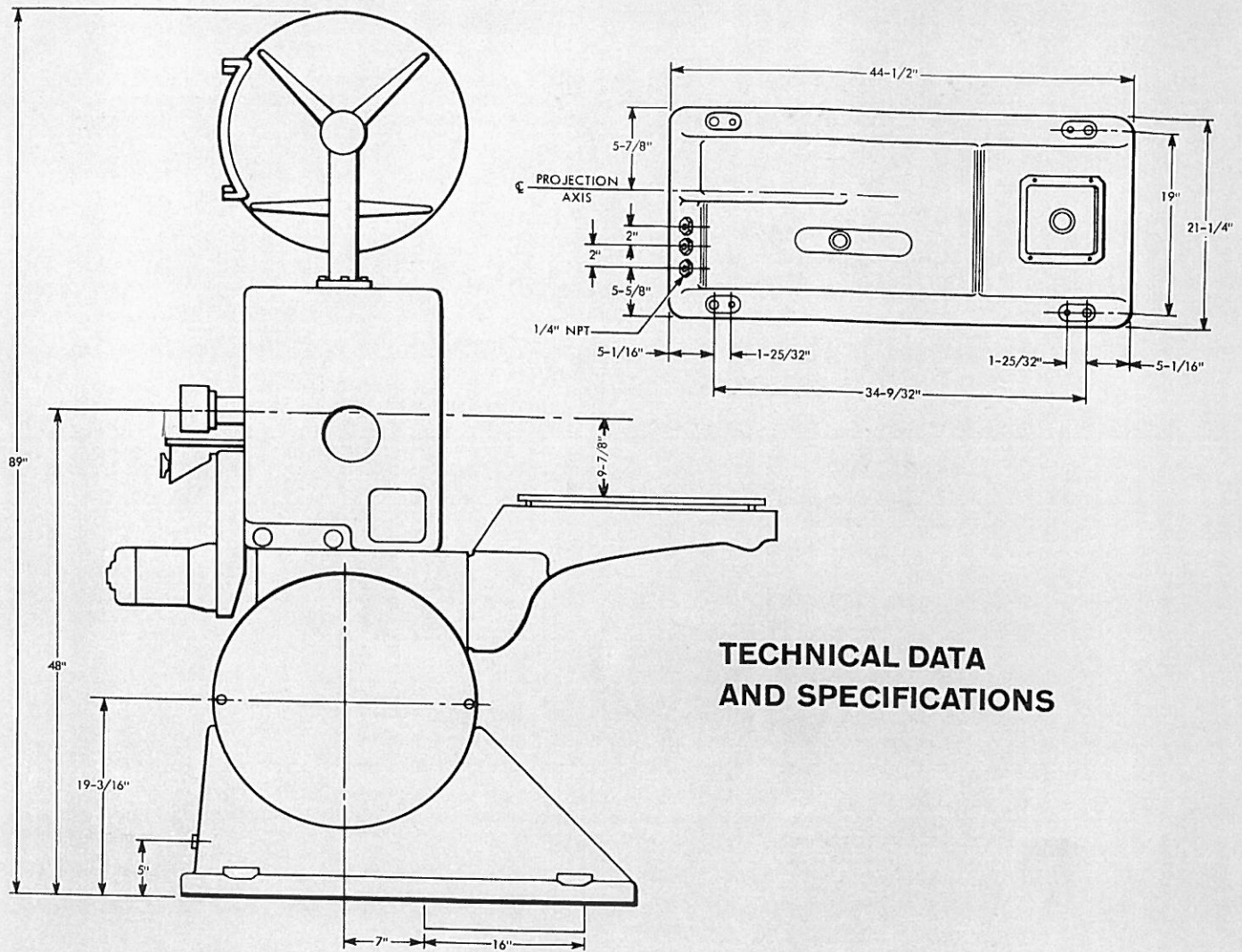

## TECHNICAL DATA AND SPECIFICATIONS

**REEL DIAMETER:** 22 inches.

**MOTOR:** 1800 R.P.M., Synchronous, 115 volts, 60 cycles.

**PHOTO CELL:** Type 918.

**EXCITER LAMP:** 4 Ampere, 9 volts, Prefocused base.

**CHANGEOVER DOWSER:** Built-in.

**DOWSER VOLTAGE SUPPLY:** Built-in.

**WATER COOLING:** Built-in.

**PROJECTION ANGLE:** Adjustable from 15° upward to 28° downward.

**SHUTTER:** Single blade—double speed—high efficiency, conical with integral air scoops.

**LUBRICATION:** Gear driven pump—positive, triple filtered and metered flow to all points including intermittent.

**INTERMITTENT MOVEMENT:** Double bearing—heavy duty.

**FILM SPROCKETS:** Hardened aluminum alloy.

**MAGNETIC CLUSTER:** Combination 10-track, pre-aligned.

**WIRING:** Internal wiring factory installed.

**OPTICAL SOUND:** Built-in optical pre-amplifier, 500 ohm output impedance. Optional.

**MAGNETIC SOUND:** Adaptable to all modern multi-channel amplifier systems.

**SHIPPED IN WOOD CRATES CONSISTING OF:**

Projector mechanism with built-in magnetic sound head; lower base; upper base with internal wiring, take-up drive and lower magazine; upper magazine; arc lamp bracket, motor with 2 speed drive; projector door and accessory parts. One tool and lubricant kit is supplied with each pair of projectors. Two optical pre-amplifiers with housings are packed in a separate carton as optional items.

**WEIGHT**—per projector—1605 lbs. gross, 1026 lbs. net.



**UNDERWRITERS' APPROVED.** North American Philips Company, Inc. reserves the right to make changes in design, construction and specifications, details of which do not appear in this catalog issue. Supplemental data is available on changes which may have been necessary due to operational or design modifications and improvements.



OTHER FINE *Norelco* PROJECTORS for theatres, studios, laboratories, commercial and institutional installations.

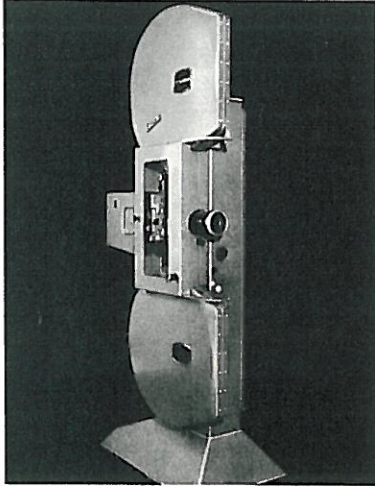

**NORELCO PULSE-LITE PROJECTOR** the first truly new 35mm projector in 40 years. Developed specifically for small and medium size theatres. Has no shutter, no arc lamp, no carbons.

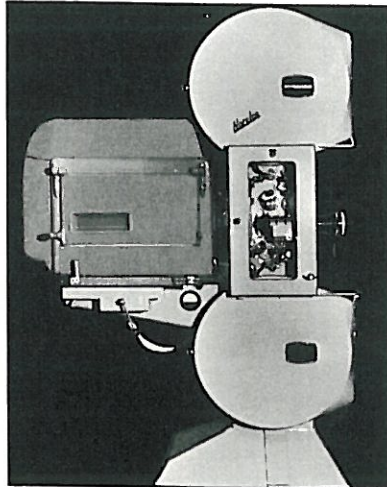

**NORELCO FP-20 PROJECTOR** precision engineered 35mm projector that incorporates every possible consideration for dependability, simplicity and ease of operation.

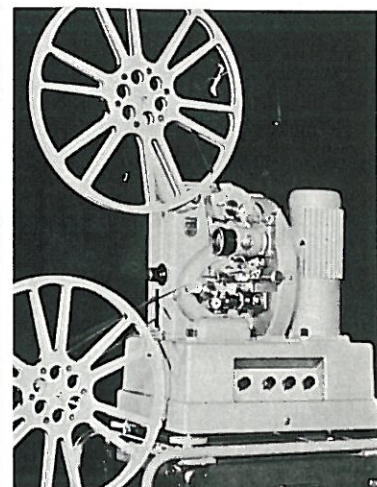

**NORELCO PROFESSIONAL 16mm SOUND-FILM PROJECTORS** designed to the same high standards as Norelco 70mm and 35mm equipment. Widely used by theatres, studios, armed forces, schools, hospitals, ships, industry, hotels, etc.

Distribution and servicing of all motion picture equipment is handled by factory trained Norelco personnel as well as established and experienced theatre supply dealers located from coast to coast. Replacement parts depots are strategically maintained for prompt, problem-free delivery... generally within hours.



**NORTH AMERICAN PHILIPS COMPANY, INC.**  
100 EAST 42ND STREET, NEW YORK 17, NEW YORK